

# SECTION 4 - FUEL/LUBRICATION/COOLING

4

---

---

## TABLE OF CONTENTS

---

Carburetor Specifications .....	4-2
Carburetor Schematic .....	4-2
Carburetor .....	4-3
Cleaning and Inspecting Carburetor.....	4-6
Throttle Cable Free-Play .....	4-8
Engine RPM (Idle).....	4-8
Gas Tank .....	4-9
Gas Tank Valve .....	4-9
Gas/Vent Hoses .....	4-10
Electric Fuel Pump .....	4-10
Oil Flow Chart .....	4-10
Testing Oil Pump Pressure.....	4-11
Oil Pressure Relief Valve.....	4-11
Liquid Cooling System .....	4-12
Radiator.....	4-13
Hoses/Thermostat.....	4-14
Fan .....	4-14
Water Pump/Alternator Cover .....	4-15
Testing Electric Fuel Pump.....	4-16

# Carburetor Specifications

ITEM	
Type	Keihin CVKR-D32 (2)
Main Jet	122 (Front)/122 (Rear)
Slow Jet	40
Pilot Screw Setting (turns)	2 1/2
Needle Jet	3.6 #3
Jet Needle	BZL-2.470
Idle RPM	1050-1150
Float Arm Height	3-5 mm (0.12-0.20 in.)
Throttle Cable Free-Play (at lever)	3-6 mm (1/8-1/4 in.)

## Carburetor Schematic

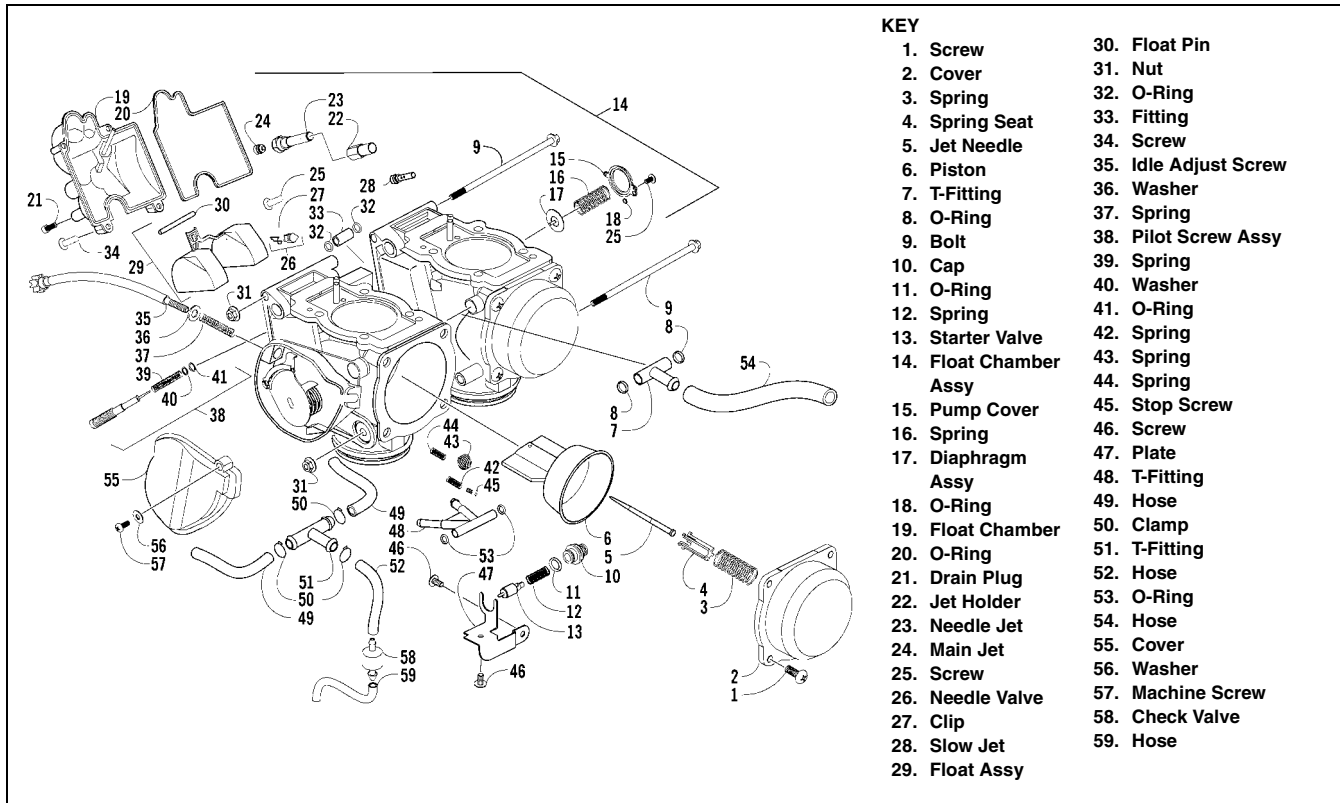

- KEY**
- |                   |                       |
|-------------------|-----------------------|
| 1. Screw          | 30. Float Pin         |
| 2. Cover          | 31. Nut               |
| 3. Spring         | 32. O-Ring            |
| 4. Spring Seat    | 33. Fitting           |
| 5. Jet Needle     | 34. Screw             |
| 6. Piston         | 35. Idle Adjust Screw |
| 7. T-Fitting      | 36. Washer            |
| 8. O-Ring         | 37. Spring            |
| 9. Bolt           | 38. Pilot Screw Assy  |
| 10. Cap           | 39. Spring            |
| 11. O-Ring        | 40. Washer            |
| 12. Spring        | 41. O-Ring            |
| 13. Starter Valve | 42. Spring            |
| 14. Float Chamber | 43. Spring            |
| 15. Pump Cover    | 44. Spring            |
| 16. Spring        | 45. Stop Screw        |
| 17. Diaphragm     | 46. Screw             |
| 18. O-Ring        | 47. Plate             |
| 19. Float Chamber | 48. T-Fitting Assy    |
| 20. O-Ring        | 49. Hose              |
| 21. Drain Plug    | 50. Clamp             |
| 22. Jet Holder    | 51. T-Fitting         |
| 23. Needle Jet    | 52. Hose              |
| 24. Main Jet      | 53. O-Ring            |
| 25. Screw         | 54. Hose              |
| 26. Needle Valve  | 55. Cover             |
| 27. Clip          | 56. Washer            |
| 28. Slow Jet      | 57. Machine Screw     |
| 29. Float Assy    | 58. Check Valve       |
|                   | 59. Hose              |

0739-201

---

---

# Carburetor

---

## WARNING

Whenever any maintenance or inspection is performed on the fuel system during which there may be fuel leakage, there should be no welding, smoking, open flames, etc., in the area.

## TROUBLESHOOTING

1. Drain float bowls into a clean, clear container. Look for rust particles, water droplets, or other contamination.
2. Momentarily turn the ignition switch to the ON position. Fuel should resume flowing indicating fuel supply to the carburetors is normal.

## CAUTION

Do not leave ignition switch on as fuel will be pumped to the carburetors and a spill could occur.

3. Dispose of the drained fuel properly; then move the ATV outside or to a properly ventilated engine run area.
4. Start the engine and warm up to operating temperature; then attach a tachometer and adjust the idle RPM to 1050-1150 RPM. Turn the handlebar full left and full right. If RPM changes, check for throttle cable adjustment or improper routing.
5. Rock carburetors from side to side and note RPM. Air leaks will cause RPM to increase. Tighten all clamps, boots, and hoses. Inspect for cracks.
6. Check the air filter housing and air filter for water, fuel, dirt, or other contamination. Wash or replace if necessary.
7. Check pilot adjustment by turning pilot screws in until lightly seated; then back out 2 1/4 turns. If no change in RPM is noted as the screws are turned in, check for an air leak between the carburetor and the cylinder head.

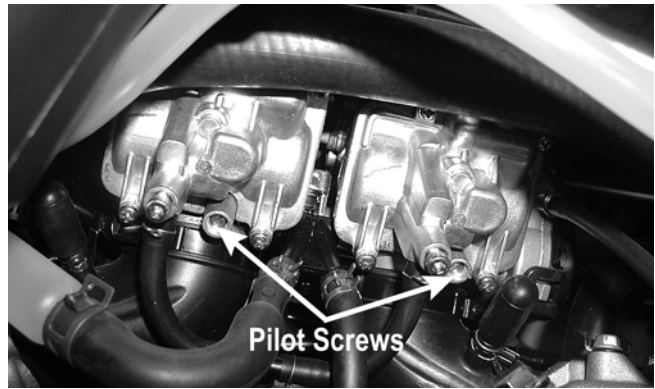

KX025E

8. Check for proper carburetor synchronization by attaching suitable vacuum gauges to the test ports; then start the engine and increase the RPM above idle. The gauges should read within 2 cm/Hg (0.78 in./Hg) of each other. Turn the synchronization screw to equalize vacuum.

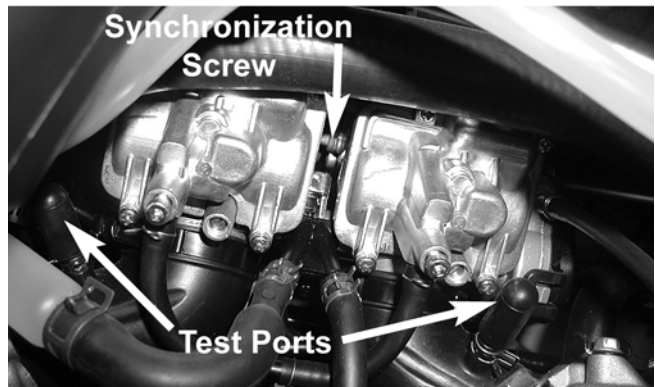

KX025C

■ **NOTE:** Idle RPM must be reset any time the synchronization screw is adjusted.

## REMOVING

1. Turn the gas tank valve to the OFF position.
2. Remove the seat; then drain the coolant.
3. Remove the storage compartment cover and air filter housing cover; then remove the air filter.
4. Disconnect the hoses from the carburetors to the gas tank valve connection.
5. Remove the screws securing the lower air filter housing to the carburetors; then remove the lower housing and tape over the carburetor inlets.

## CAUTION

Severe engine damage will occur if hardware items or other foreign objects are ingested by the engine on start-up.

4



KX118

8. Loosen the outer jam nut securing the throttle cable to the carburetor body; then route the cable out of the way.

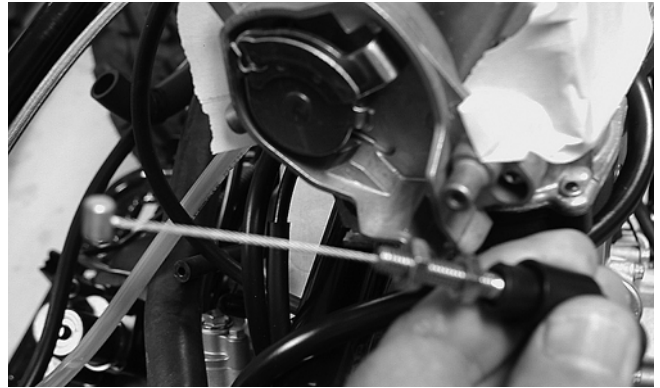

KX137



CKX119

6. Remove the screw securing the throttle actuator cover to the front carburetor; then remove the cover.

9. Remove the Phillips-head screws holding the cable end plates (A); then pull out the starter plungers and set aside.

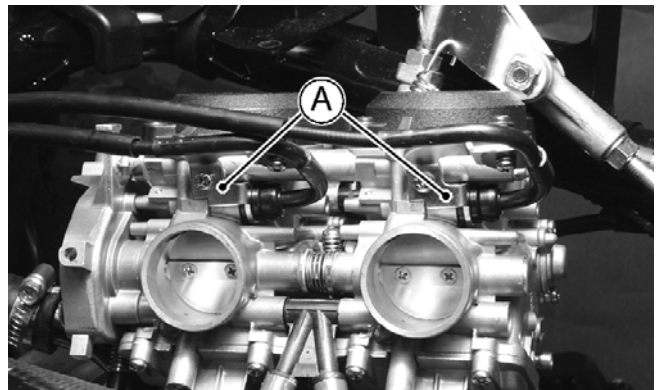

KX367



KX136

7. Remove the throttle cable from the actuator arm.

10. Disconnect the coolant hoses, breather tubes, and intake tubes; then remove the carburetors.

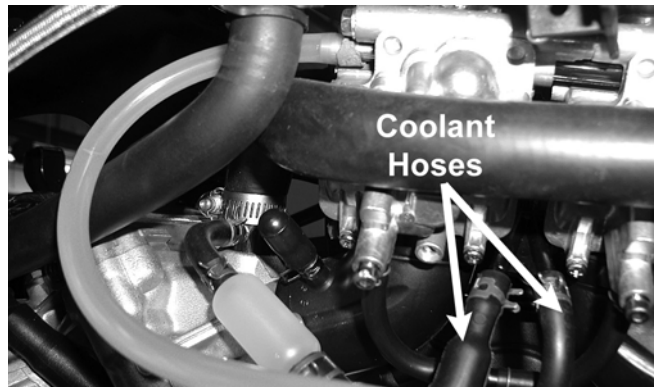

KX086B

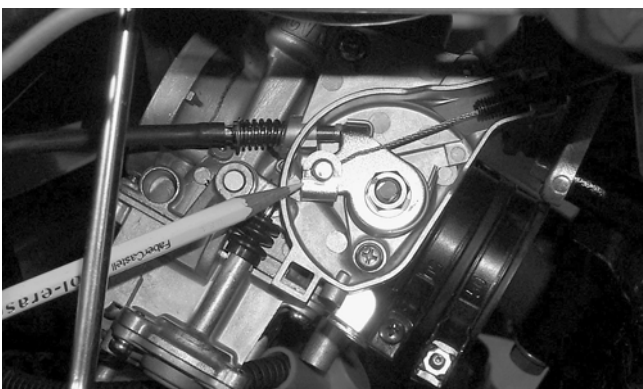

CC742

11. Use tape to cover and seal the intake tubes.



KX122

**⚠ CAUTION**

Any objects or liquid entering the intake tubes will fall into the engine causing severe damage if the engine is turned over or started.

**ADJUSTING FLOAT LEVEL**

1. Drain all fuel from the carburetors; then remove the screws securing the float chamber and remove the float chamber. Account for four screws and one O-ring gasket.

**⚠ WARNING**

Whenever any maintenance or inspection is made on the fuel system during which there may be fuel leakage, there should be no welding, smoking, open flames, etc., in the area.

2. Remove the set screw (A); then slide the pivot pin (B) out and remove the float (C).

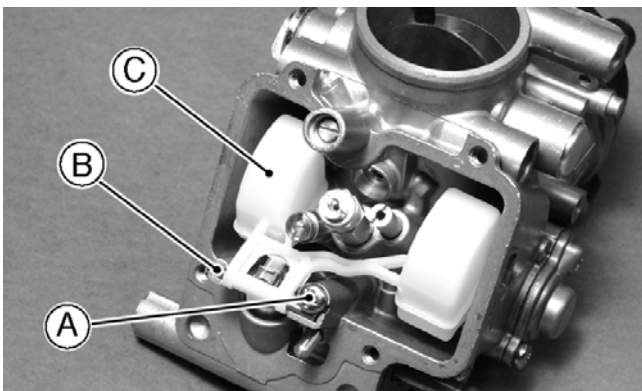

KX368

3. Bend the float valve contact tab (A) slightly to adjust float height.

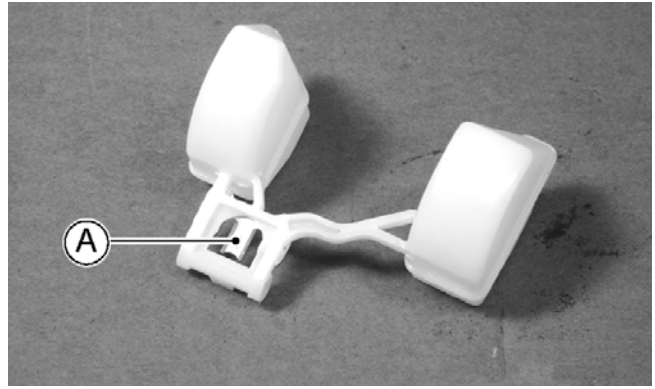

KX369

4. Measure the float height (A) from the float chamber mating surface (B) by tilting the carburetor so the float valve contact tab (C) just touches the float valve rod (D). The float valve spring (E) must not be compressed. Float height should be 3-5 mm (0.12-0.20 in.).

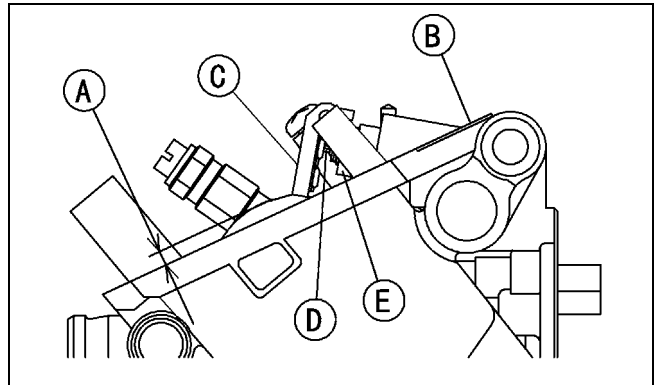

ATV2108

■ **NOTE:** Increasing the float height lowers the fuel level, and decreasing the float height raises the fuel level.

**DISASSEMBLING**

■ **NOTE:** The carburetors do not have to be separated to disassemble.

1. Remove the vacuum chamber cover (A), spring (B), and vacuum piston (C); then remove the jet needle (D) and spring seat (E) from the vacuum piston.

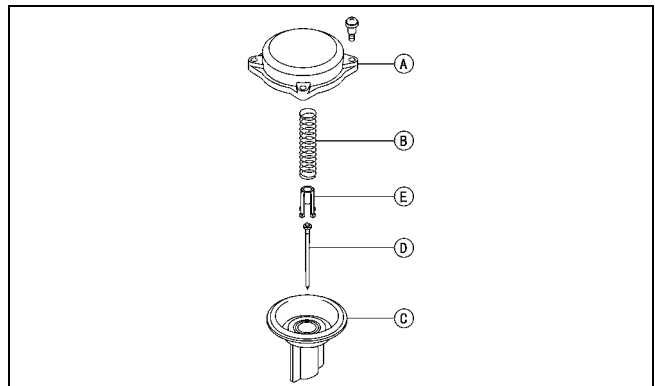

ATV2109

- Remove the four screws (A) securing the float chamber (B); then remove the float chamber. Account for the O-ring seal.

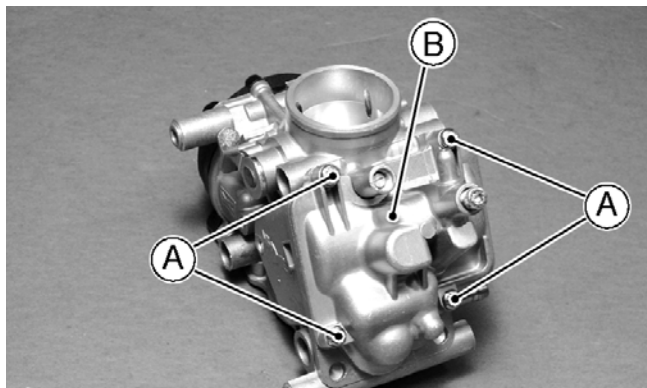

KX370

■ **NOTE:** Do not remove the pilot screws unless idle problems have been encountered. If pilot screws are removed, the carburetors will have to be synchronized after installation.

- Remove set screw (A); then remove the float pivot pin (B), float (C), needle valve, slow jet (D), and main jet (E).

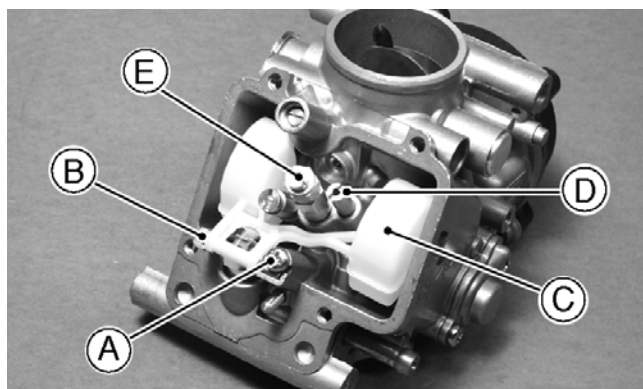

KX371

- Remove the screws (A) and pump cover (B) from the carburetor body; then remove the diaphragm (C) and O-ring (D).

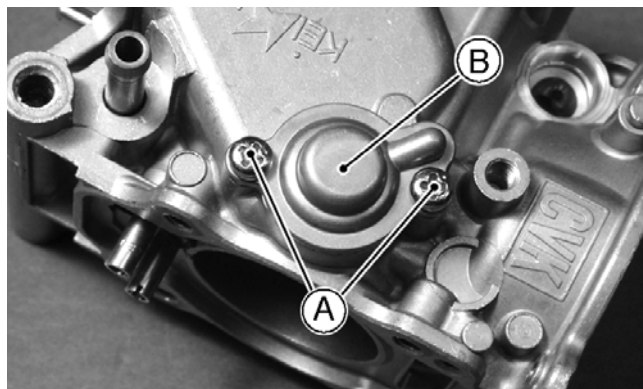

KX372

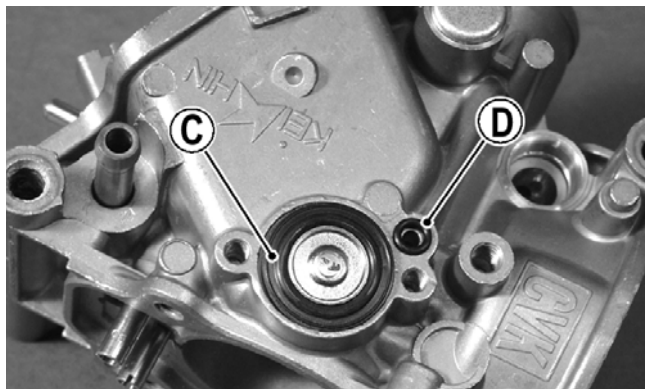

KX373A

## Cleaning and Inspecting Carburetor

■ **NOTE:** Whenever a part is worn excessively, cracked, or damaged in any way, replacement is necessary.

### ⚠ WARNING

When drying components with compressed air, always wear safety glasses.

### ⚠ CAUTION

This carburetor body has plastic parts that cannot be removed. Use only a mild, high flash-point carburetor cleaning solvent safe for plastic.

- Place all plastic components in a wire basket and submerge in carburetor cleaner.
- Soak for 30 minutes; then rinse with fresh parts-cleaning solvent.
- Wash all non-metallic components with soap and water. Rinse thoroughly.
- Dry all components with compressed air only making sure all holes, orifices, and channels are unobstructed.
- Inspect the carburetor body for cracks, nicks, stripped threads, and any other imperfections in the casting.
- Inspect the vacuum piston/diaphragm for cracks, imperfections in the casting, or cracks and tears in the rubber.
- Inspect float for damage.
- Inspect gasket and O-rings for distortion, tears, or noticeable damage.

9. Inspect tips of the jet needle, pilot screw, and the needle valve for wear, damage, or distortion.
10. Inspect the slow jet and main jet for obstructions or damage.

■ **NOTE:** If the slow jet is obstructed, the mixture will be extremely lean at idle and part-throttle operation.

11. Inspect the starter valve and seat for wear or damage.

## ASSEMBLING

### ⚠ CAUTION

**Do not force or overtighten carburetor jets and fittings. Damage to the jets or carburetor could occur.**

1. Install the needle valve into the valve seat and engage and hook the needle hanger (A) onto the float tab; then insert the float pivot pin (B) into the pivot post and tighten the set screw (C).

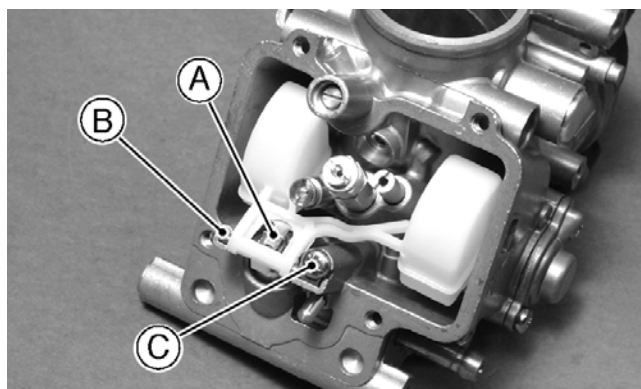

KX374

2. Install the main jet and slow jet.
3. Insert the jet needle (A) into the vacuum piston (B); then install the spring seat (C) over the needle.

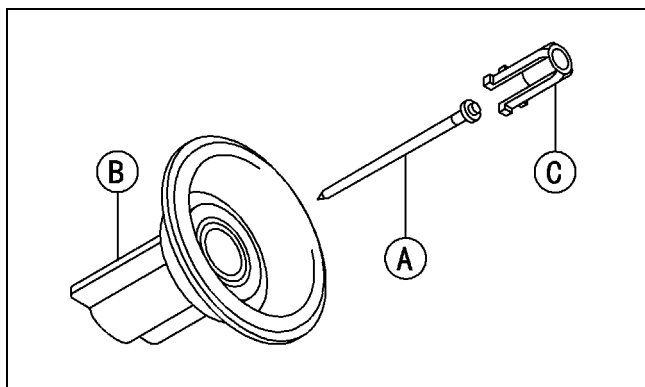

ATV2110

4. Turn the spring seat (A) so it does not block the vent hole (B).

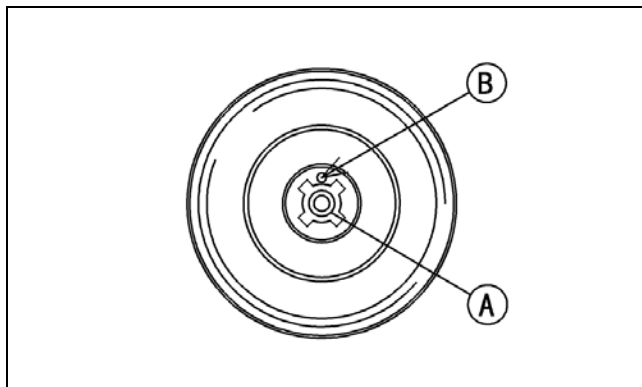

ATV2111

5. Install the piston into the carburetor body and engage the tab (A) of the diaphragm into the recess (B); then install the spring and vacuum chamber cover. Secure with four screws.

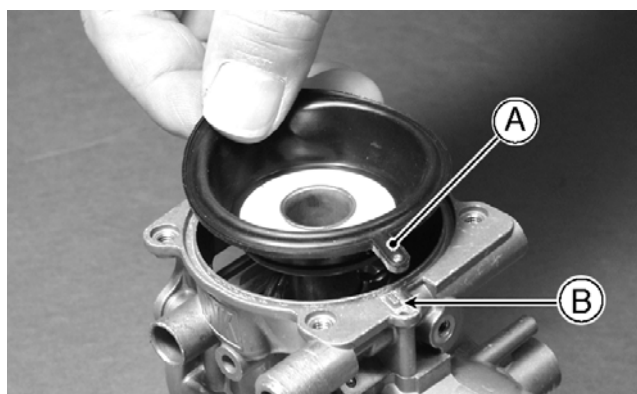

KX375

6. Install the pump diaphragm and O-ring; then install the pump cover and secure with two screws.

■ **NOTE:** Check float arm height by placing the carburetor on its side w/float contacting the needle; then measure with a caliper the height when the float arm is in contact with the needle valve. Float arm height should be 3-5 mm (0.12-0.20 in.).

7. Place the float chamber into position making sure the O-ring is properly positioned; then secure with Phillips-head screws.

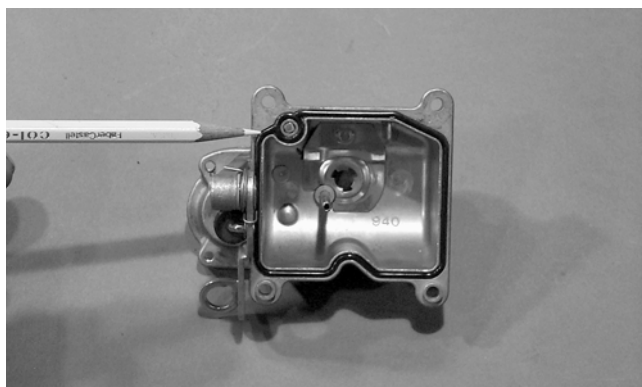

CC750

4

## INSTALLING

1. Lay the carburetor on top of the engine; then install the starter plungers and secure with the retainer screws.
2. Connect vent lines; then connect the coolant hoses.
3. Insert the carburetor into the intake tubes making sure they seat properly; then tighten the clamps securely.
4. Connect the throttle cable to the throttle actuator arm; then install the cable into the anchor housing and tighten the nuts securely.
5. Install the actuator housing cover and secure with the screws.
6. Connect the hose to the gas tank valve; then connect the carburetor float chamber drains and route outlet hose behind engine.
7. Install the air filter housing onto the carburetors and secure with eight cap screws; then install the air filter, filter housing cover, and storage compartment cover.

---

---

## Throttle Cable Free-Play

---

1. Check throttle cable free-play at the lever; free-play should be 3-6 mm (1/8 - 1/4 in.).
2. To adjust, slide the rubber boot away from the adjuster located near the throttle lever. Loosen the jam nut and rotate the adjuster in the appropriate direction until proper free-play is attained. Tighten the jam nut against the adjuster; then slide the rubber boot over the adjuster.

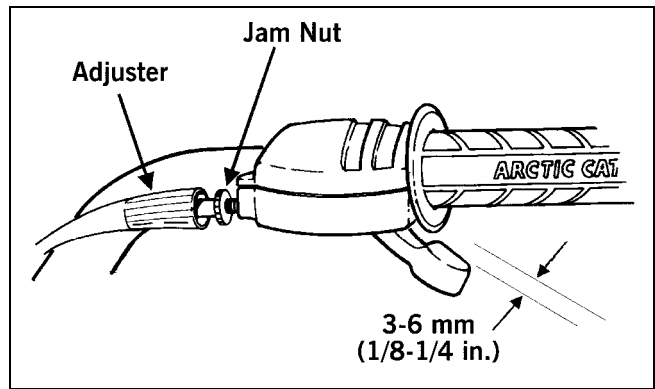

ATV-0047

---

---

## Engine RPM (Idle)

---

To properly adjust the idle RPM, a tachometer is necessary.

To adjust idle RPM, use the following procedure.

1. Start the engine and warm it up to operating temperature.
2. Turn the idle adjustment screw clockwise or counterclockwise until the engine idles at 1050-1150 RPM.

### **WARNING**

**Adjust the idle to the correct RPM. Make sure the engine is fully warm before adjusting the idle RPM.**



KX029A



# Gas Tank

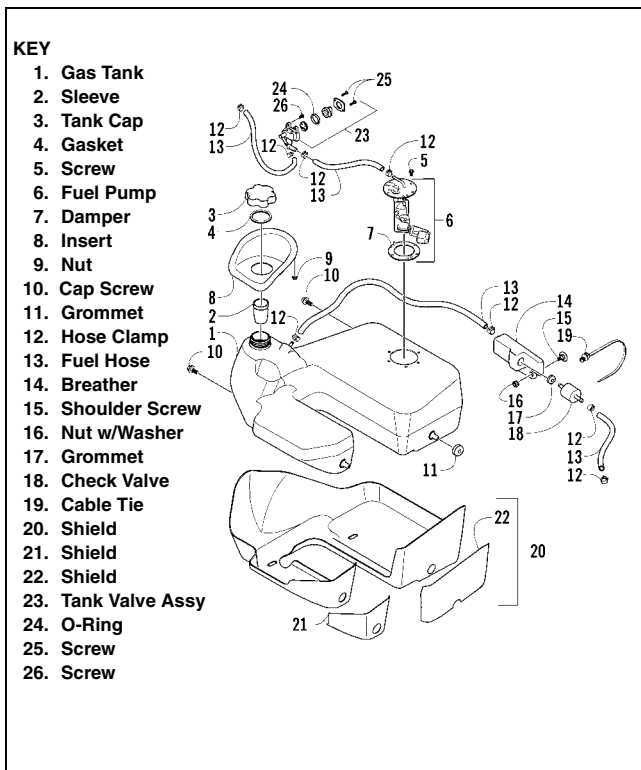

## **WARNING**

Whenever any maintenance or inspection is made on the fuel system during which there may be fuel leakage, there should be no welding, smoking, open flames, etc., in the area.

## REMOVING

1. Turn the gas tank valve to the OFF position.
2. Remove the seat.
3. Remove the rear rack and fenders.
4. Disconnect the hose from the fuel pump to the tank valve at the fuel pump.
5. Remove the cap screws securing the gas tank to the frame.
6. Disconnect the fuel pump/fuel gauge connector; then remove the gas tank.

## CLEANING AND INSPECTING

**NOTE:** Whenever a part is worn excessively, cracked, or damaged in any way, replacement is necessary.

1. Clean all gas tank components with parts-cleaning solvent.
2. Inspect all hoses for cracks or leaks.
3. Inspect tank cap and tank for leaks, holes, and damaged threads.

## INSTALLING

1. Place the gas tank into position in the frame; then install the cap screws. Tighten securely.
2. Connect the fuel hose from the gas tank valve; then connect the fuel pump/fuel gauge connector.
3. Install the vent hose; then fill the gas tank with gasoline.
4. Turn the gas tank valve to the ON position and inspect for leakage.
5. Install the rear fenders and rack; then install the seat making sure it latches securely.

# Gas Tank Valve

4

The ATV has a valve separate from the gas tank. There are two positions: ON and OFF.



KX030

In the OFF position, the valve will not allow gasoline to flow to the carburetor. In the ON position (the normal operating position), gasoline is pumped from the tank to the carburetor. The ignition switch must be in the ON position to activate the electric fuel pump. When turning the valve to either of the two positions, be sure the indicator is pointed directly at the position desired.

## REMOVING/INSPECTING

1. Remove the gas hose from the valve by releasing the spring clamp.
2. Remove the two screws securing the valve; then remove the valve.

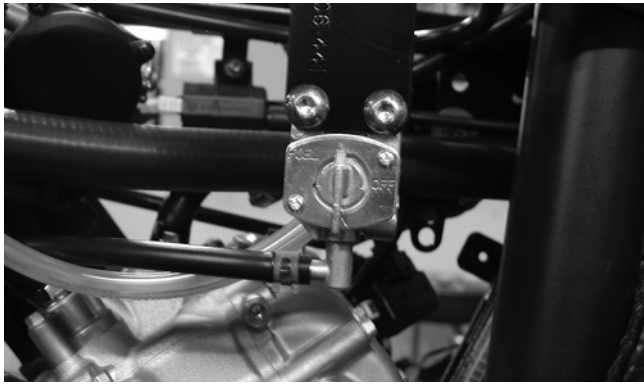

KX027

3. Inspect for and remove any obstructions in the valve.

### INSTALLING

1. Place the valve on the frame and secure with the screws. Tighten securely.
2. Install the gas hoses onto the valve with the spring clamps.

## Gas/Vent Hoses

Replace the gas hose every two years. Damage from aging may not always be visible. Do not bend or obstruct the routing of the carburetor vent hose. Make certain that the vent hose is securely connected to the carburetor and the opposite end is always open.

## Electric Fuel Pump

The electric fuel pump and fuel level sensor are a non-serviceable assembly. If either fails, the fuel pump assembly must be replaced.

■ **NOTE:** For testing the fuel pump, see **Testing Electric Fuel Pump** in this section.

## Oil Flow Chart

### KEY

1. Oil Screen
2. Oil Pump
3. Relief Valve
4. Oil Pressure Switch
5. Oil Filter
6. Oil Pipe
7. Crankshaft
8. Rear Cylinder Head
9. Rear Camshaft
10. Transmission Idle Shaft
11. Transmission Driveshaft
12. Front Cylinder Head
13. Front Camshaft

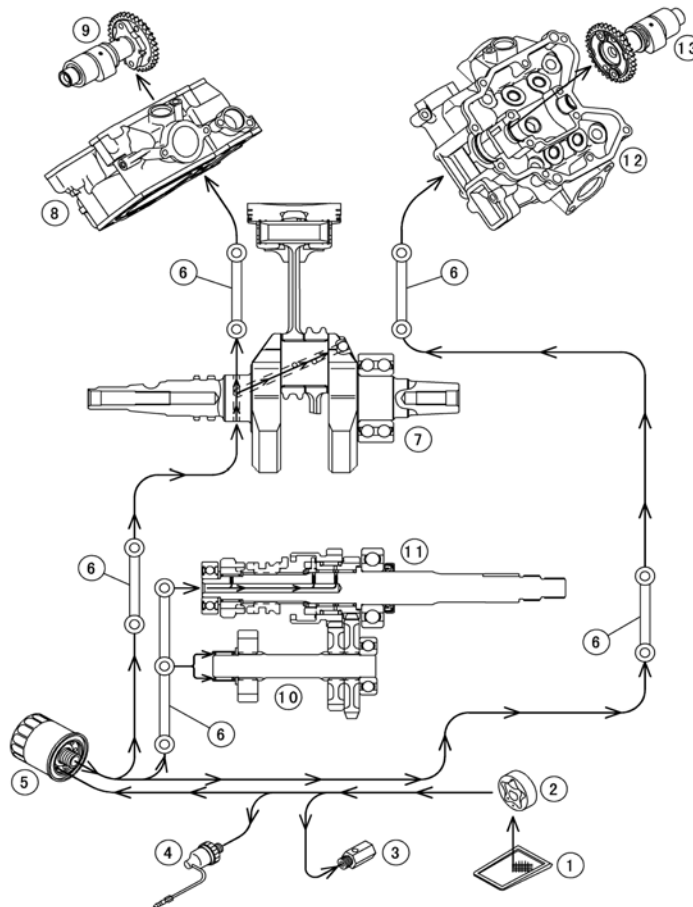

## REMOVING/DISASSEMBLING

1. Remove the oil pump from the engine (see Left-Side Components in Section 3).
2. Remove the circlip (A) on the driveshaft; then remove the inner rotor (B), outer rotor (C), oil pump driveshaft (D), and the oil pump housing (E).

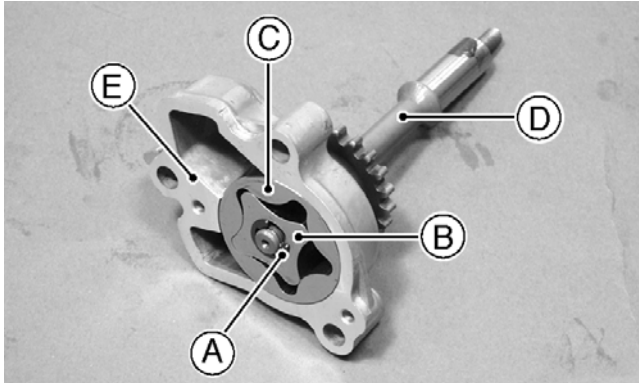

KX376

## CLEANING AND INSPECTING

■ **NOTE:** Whenever a part is worn excessively, cracked, or damaged in any way, replacement is necessary.

1. Clean all oil-pump components.
2. Inspect the rotors for scoring and gouges.
3. Inspect the driveshaft and driven sprocket for damage.
4. Inspect the pump housing for cracks or damage.

## ASSEMBLING/INSTALLING

1. Place the shaft into the pump housing; then install the inner and outer rotors and secure with a circlip.
2. Install the oil pump into the engine (see Left-Side Components in Section 3).

---

## Testing Oil Pump Pressure

---

■ **NOTE:** The engine must be warmed up to operating temperature for this test.

1. Connect the Arctic Cat Engine Tachometer (p/n 0644-275) to the engine.
2. Remove the oil pressure sender switch; then connect the Oil Pressure Gauge (p/n 0444-039) to the open port using a suitable adapter.

■ **NOTE:** Some oil seepage may occur when installing the oil pressure gauge. Wipe up oil residue with a cloth.

3. Start the engine and run at 4500 RPM.
4. The oil pressure gauge must read as 4.9 kg-cm<sup>2</sup> (69.7 psi).

■ **NOTE:** If the oil pressure is considerably lower than specified, check the pressure relief valve, for a damaged oil seal, for a defective oil pump, and/or for crankshaft bearing insert wear.

■ **NOTE:** If the oil pressure is higher than specified, check for too heavy engine oil weight (see Section 2), clogged oil passage, clogged oil filter, or improper installation of the oil filter.

4

---

## Oil Pressure Relief Valve

---

■ **NOTE:** To remove the oil pressure relief valve, the center crankcase must be separated (see Section 3).

1. Remove the oil pressure relief valve (A); then check the valve for debris or metal filings.

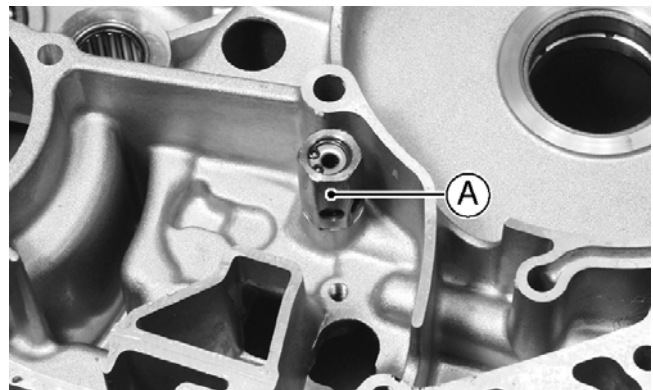

KX377

2. Using a wooden dowel (or other non-metallic instrument), apply pressure to the relief valve plunger (A) and ensure that it moves freely and returns to the closed position by the force of spring (B).

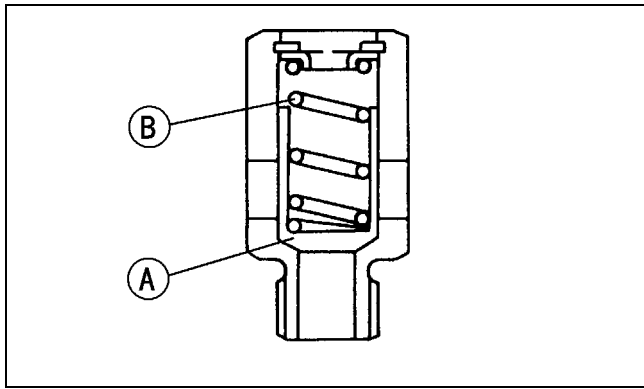

ATV2113

■ **NOTE:** The valve is not serviceable and individual parts are not available. If the plunger movement is not free and smooth, replace the valve.

### INSTALLING

1. Apply blue Loctite #242 to the threads of the oil pressure relief valve; then install and tighten to 1.5 kg-m (11 ft-lb).
2. Assemble engine (see Section 3).

3. If the valve movement is not smooth, wash in suitable solvent; then repeat step 2.

## Liquid Cooling System

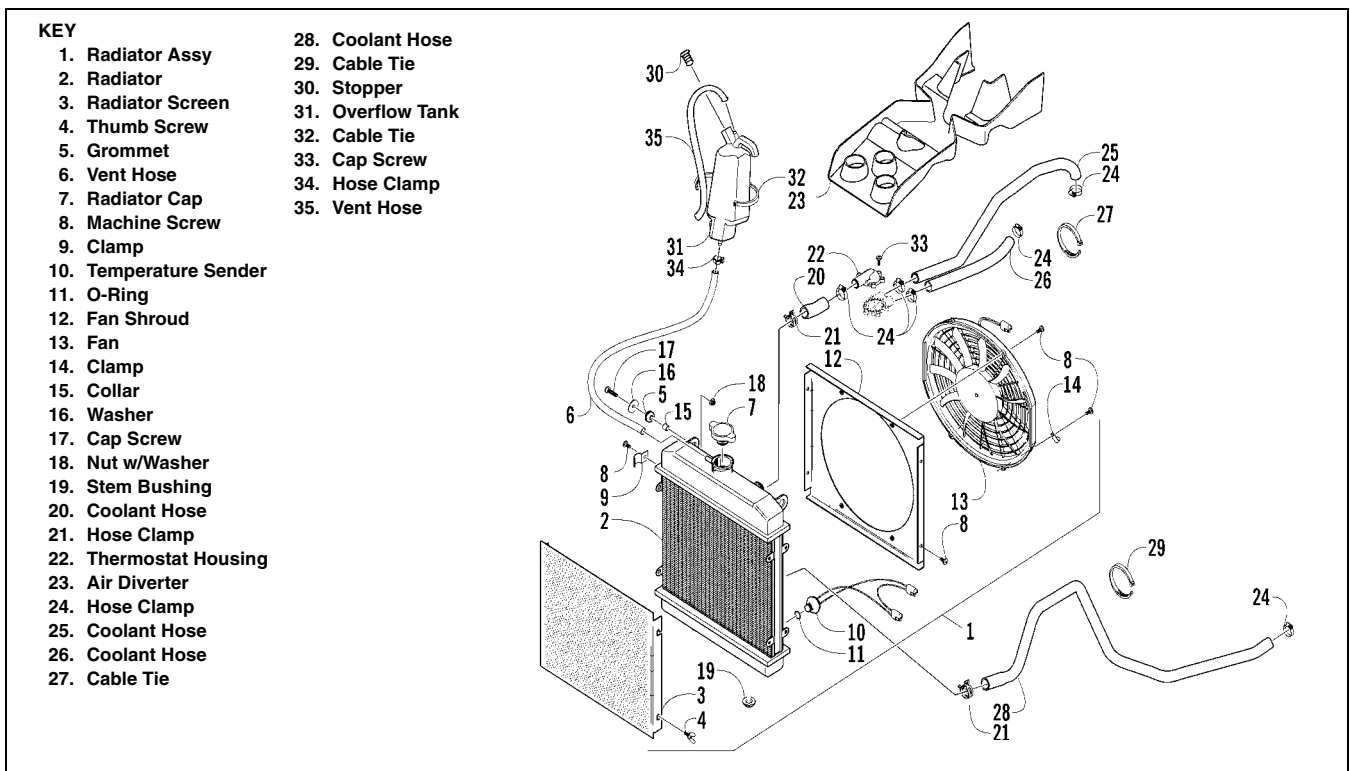

0739-135

The cooling system capacity is approximately 2.7 L (2.8 U.S. qt). The cooling system should be inspected daily for leakage and damage. Also, the coolant level should be checked periodically.

When filling the cooling system, use premixed Arctic Cat Antifreeze (p/n 0638-395). While the cooling system is being filled, air pockets may develop; therefore, run the engine for five minutes after the initial fill, shut the engine off, and then fill the cooling system to the bottom of the stand pipe in the radiator neck.



AN604D

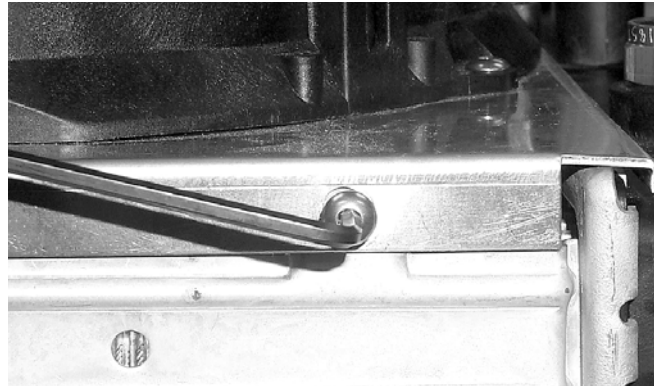

CC863

**⚠ CAUTION**

After operating the ATV for the initial 5-10 minutes, stop the engine, allow the engine to cool down, and check the coolant level. Add coolant as necessary.

## Radiator

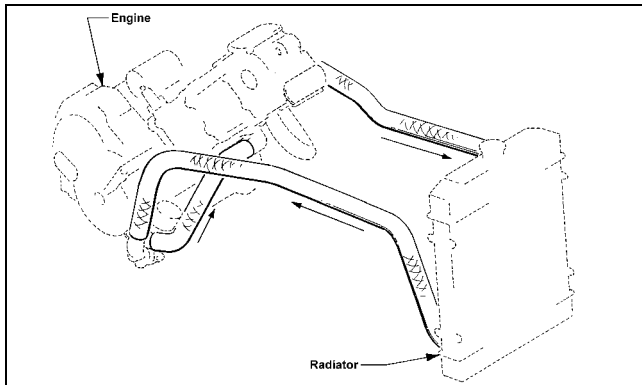

0732-411

### REMOVING

1. Drain the coolant at the engine.
2. Remove the front rack (see Section 8).
3. Remove the front bumper and grille assembly (see Section 8).
4. Remove the upper and lower coolant hoses.
5. Remove the cap screws and nuts securing the radiator to the frame.
6. Disconnect the fan wiring from the main wiring harness; then remove the radiator/fan assembly and account for the grommets and collars.
7. Remove the fan/fan shroud assembly from the radiator.

### CLEANING AND INSPECTING

■ **NOTE:** Whenever a part is worn excessively, cracked, or damaged in any way, replacement is necessary.

1. Flush the radiator with water to remove any contaminants.
2. Inspect the radiator for leaks and damage.
3. Inspect all hoses for cracks and deterioration.
4. Inspect all fasteners and grommets for damage or wear.

**4**

### INSTALLING

1. Position the fan/fan shroud assembly on the radiator; then secure with existing hardware.
2. Place the radiator with grommets and collars into position on the frame; then install the cap screws and nuts. Tighten securely.
3. Install the upper and lower coolant hoses; then secure with hose clamps.



AF734D

4. Install the front bumper and grille assembly (see Section 8).
5. Install the front rack (see Section 8).
6. Fill the cooling system (2.7 L or 2.8 U.S. qt) with antifreeze. Check for leakage.
7. Connect the fan wiring to the main wiring harness.

---

---

## Hoses/Thermostat

---

### REMOVING

1. Remove the front rack and fenders; then remove the center splash shield.
2. Drain the cooling system down approximately 1 quart.
3. Remove the cap screws securing the thermostat housing to the mounting bracket; then remove the remaining two cap screws and separate the housing and cover.

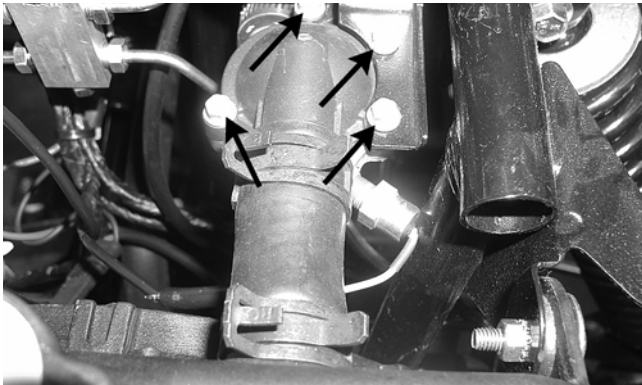

KX193A

4. Remove the thermostat and account for the seal.

### INSPECTING

■ **NOTE:** Whenever a part is worn excessively, cracked, or damaged in any way, replacement is necessary.

1. Inspect the thermostat for corrosion, wear, or spring damage.
2. Using the following procedure, inspect the thermostat for proper operation.
  - A. Suspend the thermostat in a container filled with water.
  - B. Heat the water and monitor the temperature with a thermometer.
  - C. The thermostat should start to open at 69.5-72.5°C (157-162°F).
  - D. If the thermostat does not open, it must be replaced.

3. Inspect all coolant hoses, connections, and clamps for deterioration, cracks, and wear.

■ **NOTE:** All coolant hoses and clamps should be replaced every four years or 4000 miles.

### INSTALLING

1. Place the thermostat and seal into the thermostat housing; then finger-tighten the thermostat housing to the mounting bracket with the two cap screws.
2. Install the remaining two cap screws; then tighten the four cap screws to 0.9 kg-m (78 in.-lb).
3. Fill the cooling system (2.7 L or 2.8 U.S. qt) with antifreeze. Check for leakage.
4. Install the center splash shield; then install the fenders and front rack.

---

---

## Fan

---

### REMOVING

1. Remove the radiator (see Radiator in this section).
2. Remove the fan assembly from the radiator.



CC862

### INSTALLING

1. Position the fan assembly on the radiator; then secure with existing hardware.

■ **NOTE:** The fan wiring must be in the upper-right position.

2. Install the radiator (see Radiator in this section).

# Water Pump/Alternator Cover

■ **NOTE:** Check for water pump seal leakage by examining drain catch tank (A).

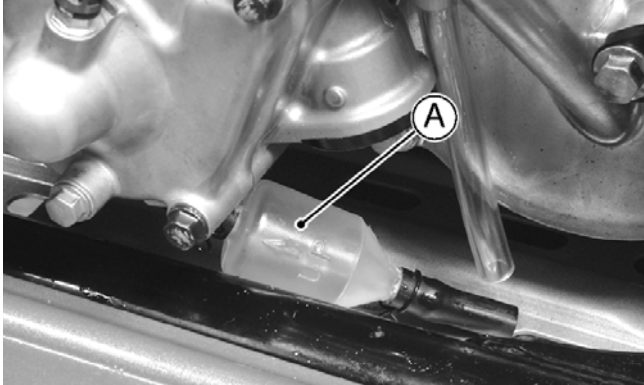

KX383

## ⓘ AT THIS POINT

If there is no coolant in the catch tank, proceed to step 1 to inspect the impeller.

1. Drain the coolant; then remove hoses (A), cap screws (B), and the water pump cover (C). Account for the gasket and two alignment pins.

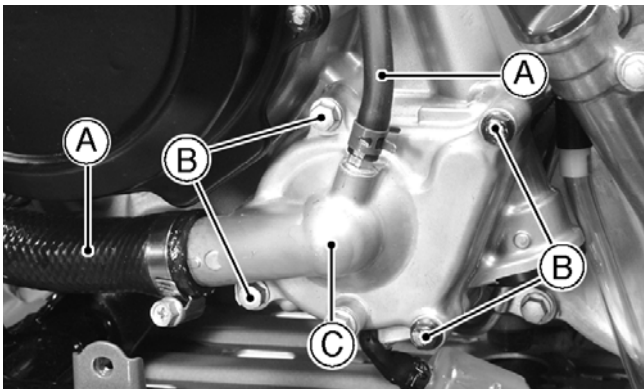

KX378

2. Remove the recoil starter (see Removing Left-Side Components in Section 3); then using a suitable holding wrench (B) to hold the starter cup (A), loosen the impeller (C) by turning counterclockwise.

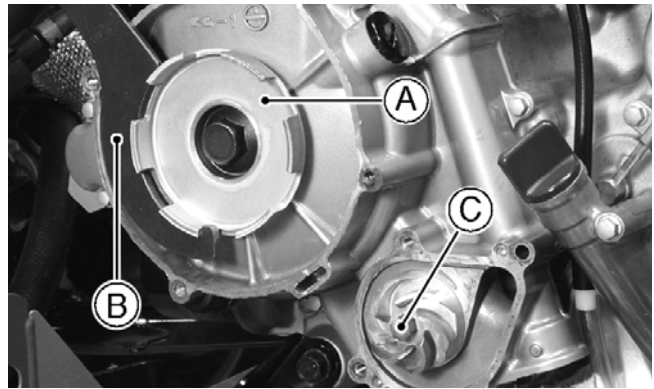

KX379

## ⓘ AT THIS POINT

If the impeller is corroded or damaged, replace the impeller; then proceed to step 10. If additional service on the water pump/alternator cover is necessary, proceed to step 3.

3. Remove the alternator cover (see Removing Left-Side Components in Section 3); then using a suitable bearing driver, remove the water pump bearing from the alternator cover.
4. Press out the mechanical seal (A) and oil seal (B) from the inside of the alternator cover using bearing driver (C).

4

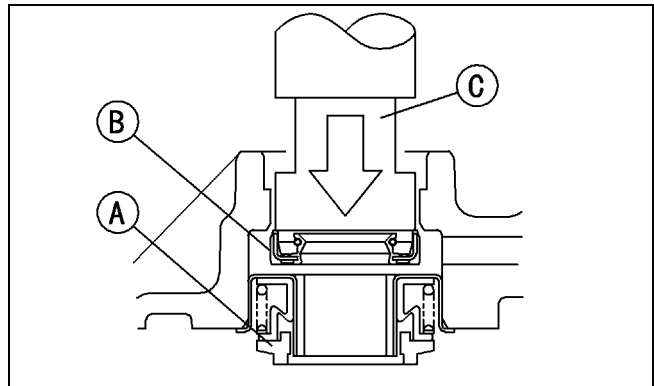

ATV2114

## ⚠ CAUTION

If the mechanical seal, oil seal, or the ball bearing is removed, always replace all three as a set. Be careful not to block the inspection hole with the oil seal. If the inspection hole is blocked, coolant will pass through the oil seal and flow into the crankcase causing severe engine damage.

5. Apply high temp grease to the oil seal lip; then press oil seal (A) from the outside of the alternator cover until flush with (B).

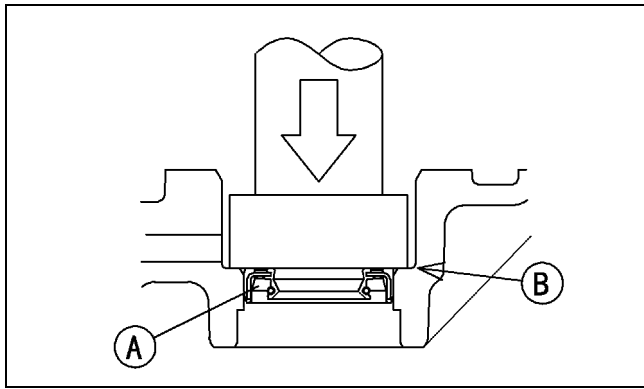

ATV2115

- Press ball bearing (A) into the alternator cover from the inside until it is bottomed; then using a suitable socket (B) and bearing driver (C), press in a new mechanical seal (D) until the flange stops at (E).

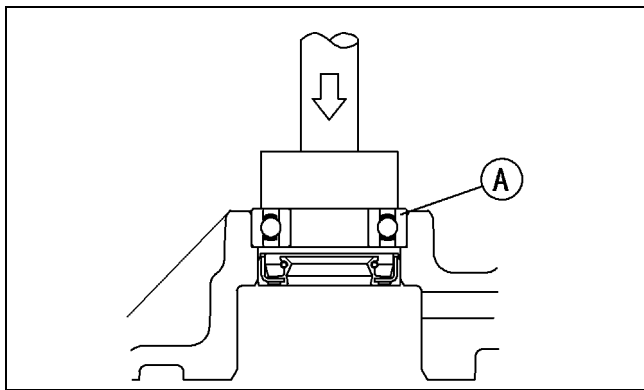

ATV2117

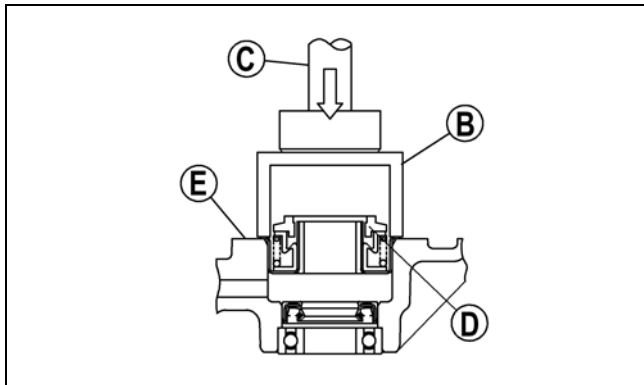

ATV2118A

- Carefully clean the sliding surfaces of the new mechanical seal with clean solvent; then apply the coolant to the sliding surface to provide initial lubrication.
- Apply coolant to the surfaces of the rubber seal and sealing seat (A); then press the rubber seal (B) and sealing seat into the impeller until the seat bottoms out.

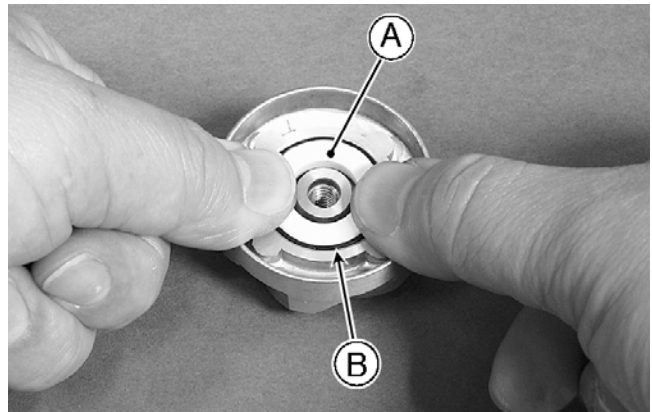

KX380

- Install the alternator cover (see Installing Left-Side Components in Section 3); then install the impeller and tighten clockwise to 0.8 kg-m (69 in.-lb).
- Make sure that the alignment pins are correctly inserted; then using a new gasket, install the water pump cover and tighten the cap screws to 0.9 kg-m (78 in.-lb).
- Install the recoil starter (see Installing Left-Side Components Section 3).
- Install the coolant hoses onto the pump cover; then fill the cooling system with recommended coolant (see Section 2).

## Testing Electric Fuel Pump

### 👉 AT THIS POINT

Prior to removing the electric fuel pump, the following check should be performed to determine that removal is necessary.

### ⚠️ WARNING

Whenever any maintenance or inspection is made on the fuel system during which there may be fuel leakage, there should be no welding, smoking, open flames, etc., in the area.

- Turn the ignition switch ON and listen for a momentary "whirring" sound of the pump building pressure. If the sound is heard (10 seconds), no electrical checks are necessary. Turn the ignition switch OFF.
- Disconnect the fuel hose from the pump to the gas tank valve; then install a suitable pressure gauge.





KX192

3. Turn the ignition switch to the ON position. The fuel pressure should build until the pump shuts off. Pressure should read 0.18-0.23 kg-cm<sup>2</sup> (2.6-3.3 psi).
4. If the pump is not running, disconnect the fuel pump/tank sensor connector by reaching under the rear rack from behind.
5. Connect a multimeter to the power supply leads with the red tester lead to the brown wire and the black tester lead to the black/red wire; then turn the ignition switch to the ON position. The meter should read battery voltage. If battery voltage is indicated and the fuel pump does not run, replace the pump assembly. If no battery voltage is indicated, check the CDI and the vehicle tilt sensor.

■ **NOTE:** To test the fuel gauge tank sensor, the fuel pump assembly must be removed.

## REMOVING

1. Remove the rear rack and fenders; then disconnect the power supply/ fuel gauge connector.



KX186

2. Remove the spring clamp; then remove the fuel hose.
3. Remove the screws securing the fuel pump to the gas tank; then make a reference mark on the fuel pump and tank.

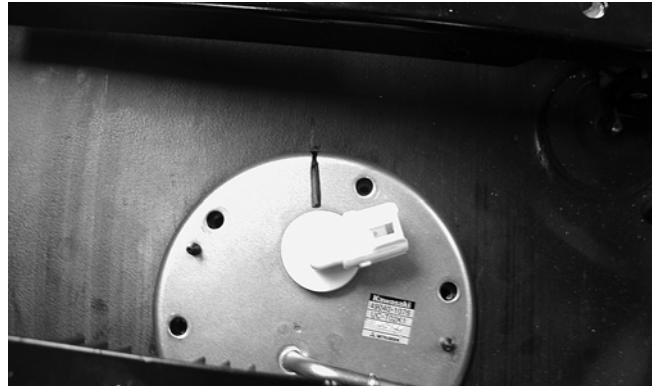

KX187

4. Rotate the fuel pump assembly clockwise 90° to allow removal without removing the fuel tank.



KX188

5. Lift out the fuel pump assembly carefully tilting it forward to clear the voltage regulator; then guide the pump and float lever through the opening in the gas tank.

## ⚠ CAUTION

Take care not to damage the float or float arm or replacement of the entire assembly will be necessary.

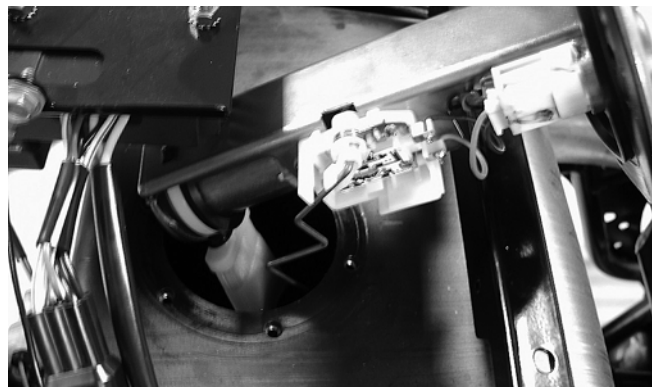

KX190

6. Using duct tape or other suitable means, cover the fuel pump opening.

## INSPECTING

### AT THIS POINT

If the pump has failed earlier test and must be replaced, proceed to INSTALLING.

1. Inspect the fuel screen and blow clean with low pressure compressed air.
2. Move the float lever and check for free movement. The float assembly should return to the lower position without force. If not, replace the fuel pump assembly.



KX191

3. Test the fuel gauge tank sensor by connecting a multimeter (A) to the fuel sensor leads (B); then select OHMS. The multimeter should show 120 ohms at full fuel position (C) and 3 ohms at empty fuel position (D).

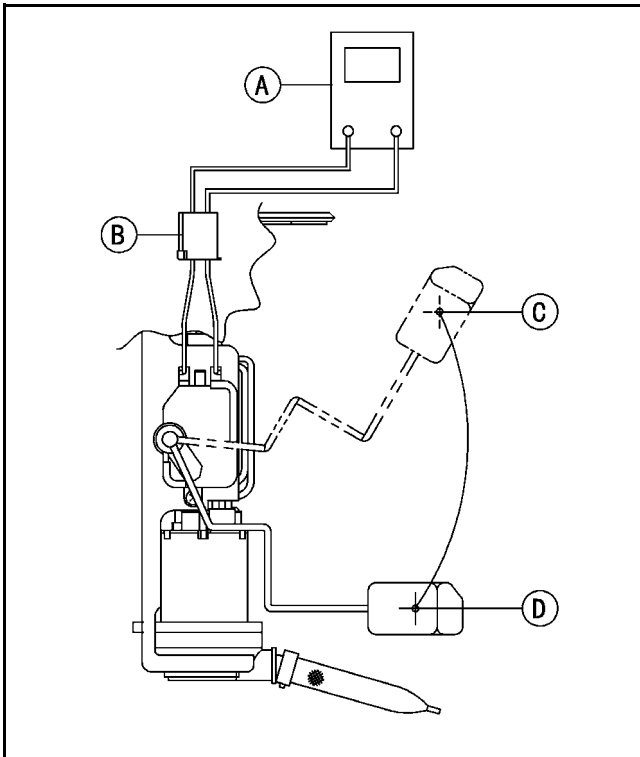

ATV2116

■ **NOTE:** If readings are erratic, clean the resistor wiper and resistor with clean alcohol and retest. If still not correct, replace the fuel pump assembly.

## INSTALLING

1. Mark the new fuel pump with a reference mark in the same location as the removed pump; then place the new gasket on the pump.
2. Remove the material covering the fuel pump opening; then carefully guide the fuel pump into position taking care not to damage the float or float lever.

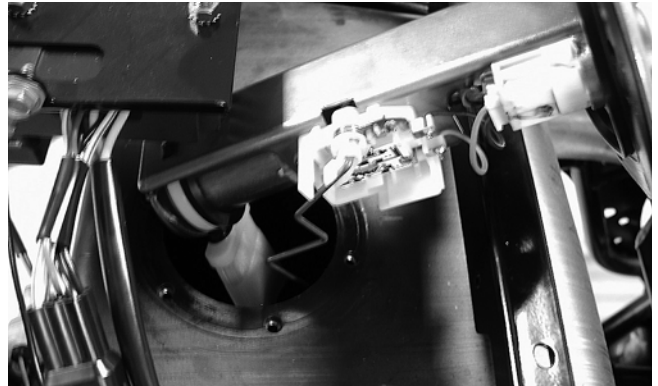

KX190

3. Rotate the fuel pump counterclockwise 90° or until the match marks align; then install the mounting screws and tighten securely using a crisscross pattern.

■ **NOTE:** It is important to install the fuel pump with the correct orientation to ensure adequate float lever clearance.

4. Connect the wires, fuel hose, and spring clamp; then turn the ignition switch to the ON position. Note that the fuel pump runs momentarily and the fuel gauge indicates the proper fuel level.
5. With the transmission in neutral and brake lever lock engaged, start the engine and check for normal operation. Check for any fuel leaks.
6. Install any wire ties that were removed; then install the rear fenders, rack, and seat making sure the seat locks securely.